

Specialty Carbon Black Performance influencing Parameters in solvent based Packaging Inks

Technical Information 1481



Table of Contents

1 Introduction to Specialty Carbon Blacks by Orion Manufacturing Technologies	3
2 Physical and chemical Properties of Specialty Carbon Blacks and their Impact on the Formulation	4
2.1 Influence of Primary Particle Size on Optical Density	6
2.2 Influence of Primary Particle Size on Gloss	7
3 Ink Quality and Print Performance	7
3.1 Influence of Solvents on the Drying Process	7
3.2 Influence of Solvents on the Ink Rheology	9
3.3 Storage Stability of Carbon Black Ink Concentrate	10
4 Variation of Printing Parameters	11
4.1 Application by K-Control Coater	11
4.2 Application by K-Printing Proofer	11
5 Colorimetric Measuring Systems and Conditions	14
6 Summary and Outlook	15

List of Abbreviations

ASTM	American Society for Testing and Materials	ISO	International Organization for Standardization
BET	Brunauer Emmett Teller (Surface Area Method)	NC	Nitro Cellulose
CCT	Correlated Color Temperature	OAN	Oil Absorption Number
CIE	Commission Internationale de l'Eclairage	OD	Optical Density
DIN	Deutsches Institut für Normung	OEC	Orion Engineered Carbons GmbH
EtAc	Ethyl Acetate	RT	Room Temperature
EPr	Ethoxy Propanol	SCB	Specialty Carbon Black
EtOH	Ethanol		

1 Introduction to Specialty Carbon Blacks by Orion manufacturing Technologies

The Furnace Black Process (figure 1) is the most common production method (95% worldwide). In this case Carbon Black is produced in a closed reactor (furnace) under defined atmosphere. The temperature necessary for pyrolysis is given by combustion of appropriate gases, the raw material is injected into the combustion chamber through

a lance. After the Carbon Black is formed, the process mixture is quenched by injection of water, also minimizing secondary reactions. The furnace process allows average primary particle sizes and structural properties of the product to be varied within wide ranges.

Figure 1
Furnace Black Process

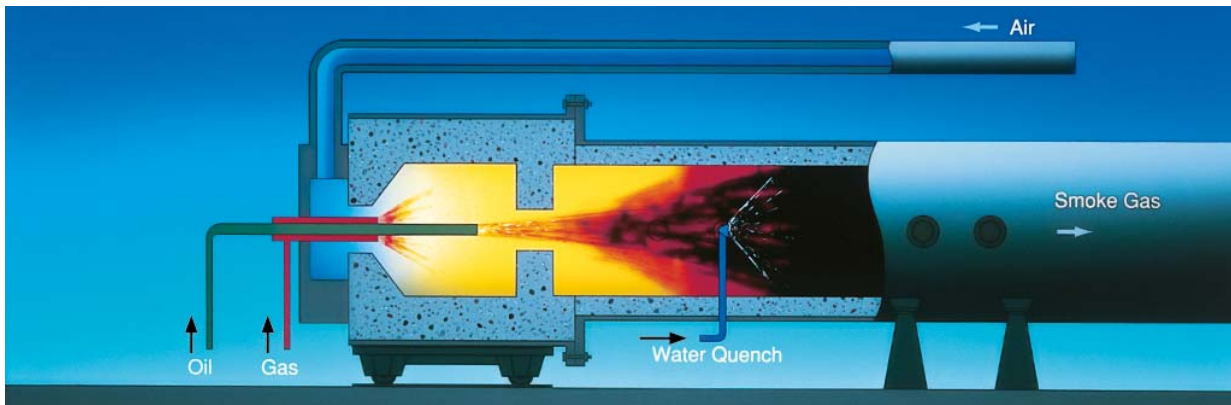

In contrast to the Furnace Black Process, during the Degussa Gas Black Process the pyrolysis occurs in the presence of atmospheric oxygen. That means the Gas Black Process uses an open reactor (figure 2), which is reflected in the volatile content of the resulting pigment surface. The process derives its name from the fact that the carbon black feedstock is vaporized by heating and is then fed to the

combustion chamber by means of a carrier gas. The Specialty Carbon Blacks produced by this method have smaller particles, which can be varied in the production process, but the influence on the structure is limited. The average primary particle size determines the intensity of blackness, known as jetness or optical density.

Figure 2
Degussa Gas Black Process

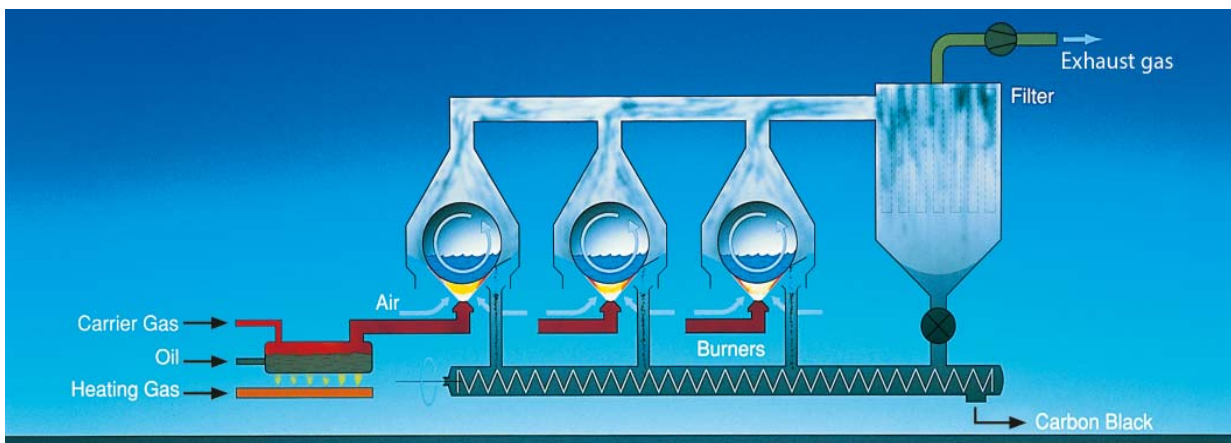

2 Physical and chemical Properties of Specialty Carbon Blacks and their Impact on the Formulation

In this technical brochure the main focus is placed on solvent based packaging inks applied by flexographic or rotogravure printing, also related to requirements for indirect food contact. The adequate use of Specialty Carbon Blacks in a specific printing application depends on their physical and chemical pigment properties defined as the following key parameters:

Physical parameters

- Average primary particle size / specific surface area (BET)
- Aggregate structure (OAN)

Chemical parameters

- Type of functional surface oxides
- pH value and content of volatile matter

The main objective of this technical information is to give guidelines how to handle and process our products efficiently, in order to achieve the best possible performance for the use of PRINTEX® grades in NC ink formulations depending on the final application.

The consideration of the parameters mentioned above is of significant importance to determine adequate formulating conditions for the Carbon Black in use with respect to binder or additive demand and pigment loading. The main influence to the dispersibility of the pigment base and to ink properties is given by the primary particle size as follows:

Figure 3

Primary Particle Size and related Properties

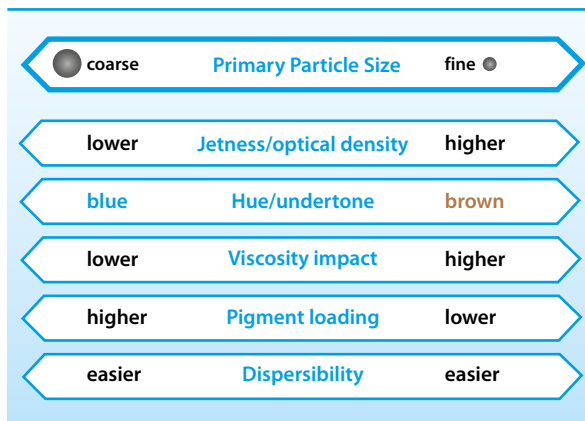

The second key parameter to be mentioned is the aggregate structure mainly affecting the same properties:

Figure 4

Aggregate Structure and related Properties

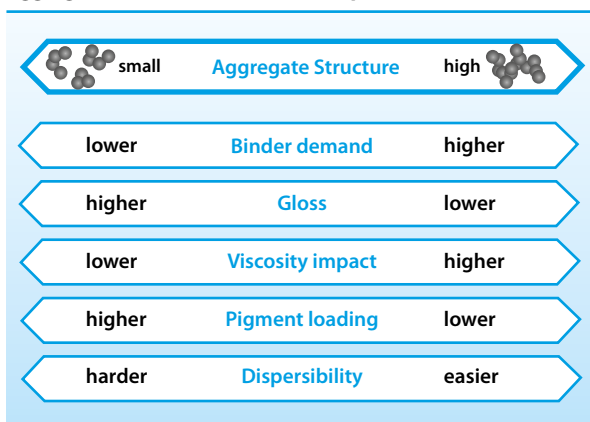

These general relationships do apply under conditions of optimized dispersion level. In case the dispersing conditions are not tailor made for the Specialty Carbon Black, the final results in terms of optical density, viscosity and gloss may differ. Therefore it is mandatory to adjust the binder/pigment ratio as well as the Carbon Black loading to an optimum level, in order to utilize a Specialty Carbon Black in the most efficient way. The combination (figure 5) of both key parameters results in different dispersing properties, which have to be considered to achieve an optimum degree of dispersion. This technical information should help to better understand certain effects and to design pigment testing experiments most effectively.

Figure 5

Dispersing Properties depending on Combination of Structure and Particle Size

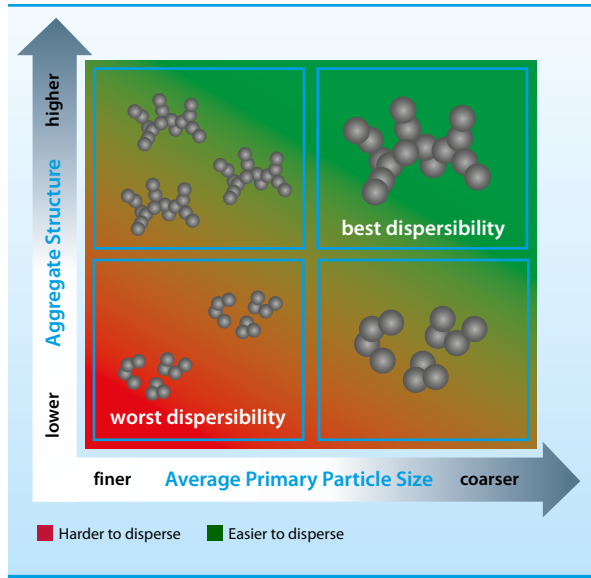

The technical data of the following Specialty Carbon Blacks are relevant for the various examples in this brochure and are given in the table below. Both parameters the BET surface area and the OAN are of main interest.

Table 1

Technical Data of low structured PRINTEX® Furnace Blacks from OEC

	Blackness Value M_v	Relative Tint Strength IRB 3 = 100%	Volatile Matter at 950°C	Oil Adsorption Number	pH Value	Ash Content	BET Surface Area	Average Primary Particle Size
Specialty Carbon Black		%	%	ml/100g		%	m ² /g	nm
PRINTEX® 55	250	127	1.2	49	9,5	0.6	110	25
PRINTEX® 45	246	117	0.9	54	9.0	0.3	90	26
PRINTEX® 35	236	100	0.5	42	9.0	0.3	60	31

The post-treatment of Carbon Blacks corresponds to a chemical modification of the pigment surface resulting in functional groups like carboxyl, lactol, phenol. Therefore an after-treated pigment exhibits several acidic groups on its surface and improves ink properties in certain binder systems.

2.1 Influence of Primary Particle Size on Optical Density

Lab studies on the basis of PRINTEX® 35 BEADS and PRINTEX® 55 BEADS were performed, in order to compare low structured pigments with different primary particle sizes in the following NC flexographic formulation listed in table 2:

Table 2

Guideline Formulation for NC solvent based Flexographic Inks

Composition of NC Black Base	
NC-Wool AH 27 (65% from Hagedorn)	17 %
Ethanol	67 %
Specialty Carbon Black	16 %
Let Down Step by Addition of	
Ethanol	60 %
NC-Wool AH 27	28 %
Dowanol PM	12 %

The Specialty Carbon Blacks were ground with a LAU Disperser DAS 200 by adding zirconium silicate as grinding media. In case of PRINTEX® 35, which is widely used in liquid flexible packaging inks the binder/pigment ratio is optimized being 69% solid on pigment in the black base. This explains why the optical density measured after 60 min is already high and will not further increase (figure 6), illustrated by the parallel line in the blue marked field. These experiments were also done at lower and higher pigment loadings with 12% and 20% respectively, by confirming

the same coloristic tendency compared to the pigment base with 16%.

In contrast to PRINTEX® 35, PRINTEX® 55 is not finally dispersed after 60 min and therefore shows an improvement of 0.2 points in optical density with longer dispersing time. The final jetness in case of PRINTEX® 55 is reached after 180 min and is not further improved after 240 min of dispersing time.

Figure 6

Optical Density of PRINTEX® 35 BEADS and PRINTEX® 55 BEADS of 12 µm Drawdowns with Dryer at 16% Pigment Loading depending on Dispersing Time

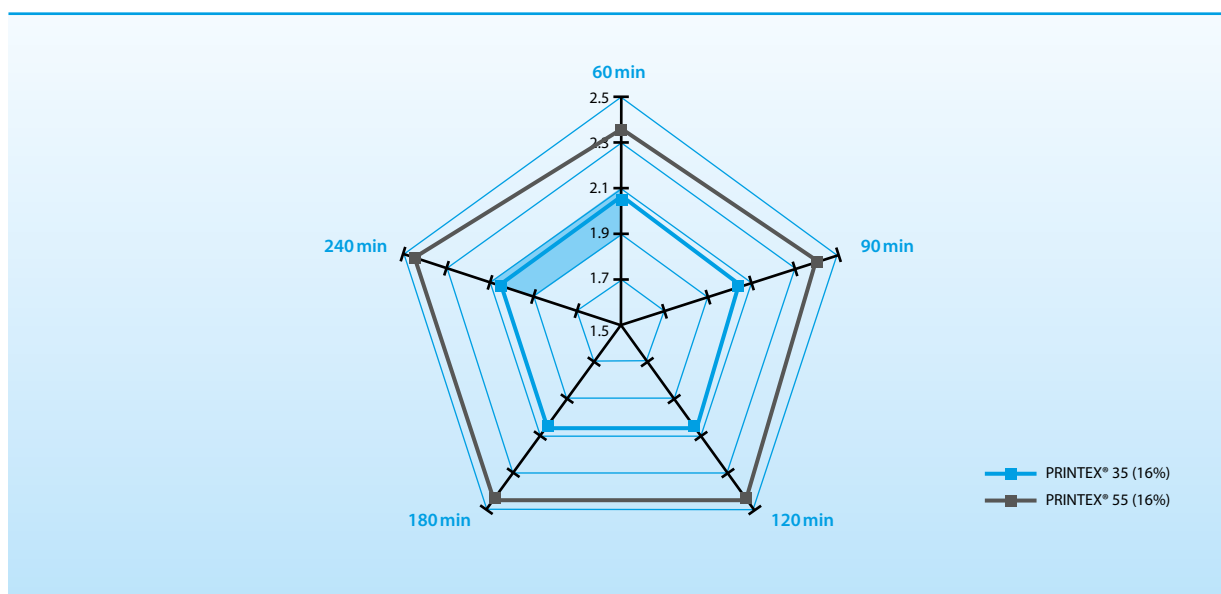

2.2 Influence of Primary Particle Size on Gloss

When considering the gloss values in figure 7, they depend on both parameters the dispersing time as well as the pigment loading. The dispersions based on PRINTEX® 35 BEADS and PRINTEX® 55 BEADS show increasing gloss with longer dispersing time. A pigment concentration of 20% leads to the highest gloss values for both Carbon Blacks. The maximum level is achieved after 180 min of dispersing

time, further dispersing efforts during additional 60 min do not affect the gloss any more, meaning an optimized dispersion is achieved. The gloss values were determined with the haze-gloss meter from BYK-Gardner at 60° geometry. The finer the average particle size, the higher the gloss level to be expected in the final ink, when the SCB is fully dispersed.

Figure 7

Gloss of PRINTEX® 35 BEADS and PRINTEX® 55 BEADS of 12 µm Drawdowns with Dryer depending on Pigment Loading and Dispersing Time

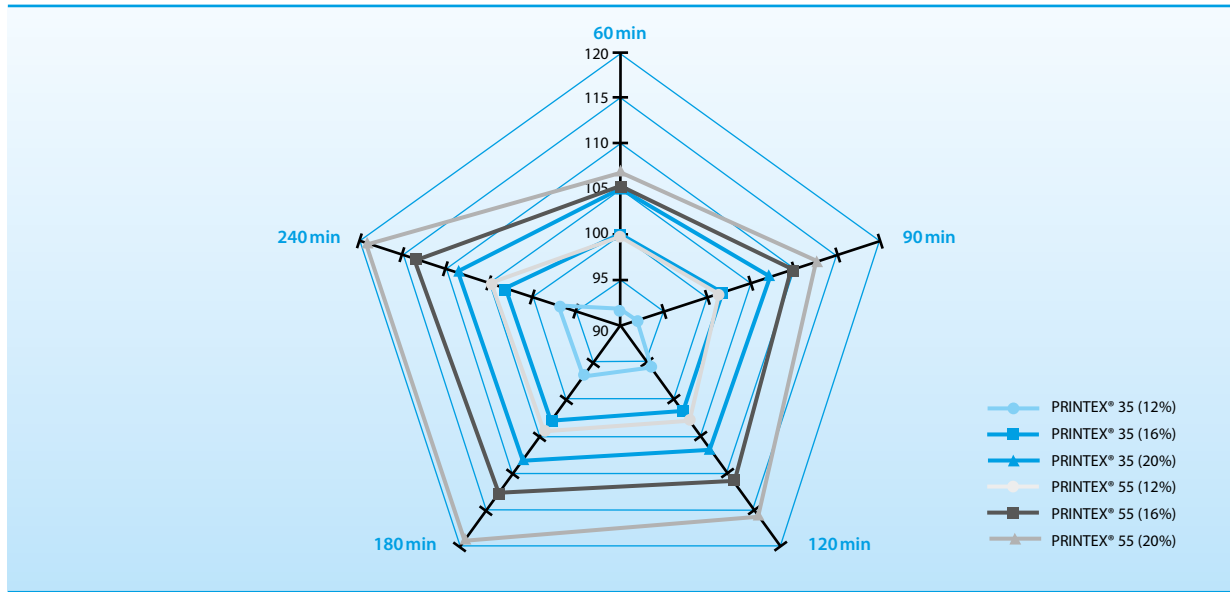

3 Ink Quality and Print Performance

The final print result depends not only on the ink quality of course, but also on the kind of substrate, the drying conditions and the viscosity to be adjusted for the printing process. The main influence for the drying speed is given by the viscosity of the solvent or solvent mixture in use. Therefore it is important to know the relevant characteristics of each solvent to be used for viscosity adjustments. In this content the thinning factor has to be mentioned, which defines the capacity of solvents to reduce the ink viscosity. Usually a preferential thinning factor achieves a significant reduction in viscosity by small solvent additions.

3.1 Influence of Solvents on the Drying Process

In general organic solvents are categorized depending on their boiling point. In case of printing ink applications the evaporation process is more significant, in order to adapt processing parameters.

Table 3**Standardized Classification of Evaporation Ranges for organic Solvents**

	Evaporation Index Range [-]
Highly Volatile	10
Medium Volatile	10 - 35
Low Volatile	35 - 50
Very low Volatile	> 50

The print operator normally refers to the classification of solvents according to the evaporation rate. The following table 4 presents the evaporation index of established solvents used in the flexographic packaging process:

Table 4**Evaporation Index of typical organic Solvents used in Flexographic Packaging Printing Industry**

	Evaporation Index [-]
Ether	1.0
Ethyl acetate	2.9
Ethanol	8.3
Ethoxypropanol	33.0

Once the ink is applied onto the substrate, the physical drying process is starting. In this content the composition of solvent mixtures is of importance. Due to the evaporation of solvents the ink film is cooling down. Especially in case of highly volatile solvents the film temperature decreases in a way that humidity condenses onto the printed film as milky appearance. In order to avoid such disturbing factors, the drying process has to be controlled by

adding hydrophilic solvents like ethoxy propanol. Another possibility is to heat the proof immediately after the film application process by means of hot air. Therefore it is very important to consider the humidity level before applying the ink. The optimum range for the print application is up to 70% of humidity in the ambient air, above unwanted haze is more difficult to avoid.

Table 5**Solvent or solvent mixture Amounts for Inks adjusted to 17 sec in DIN 4 Flow Cup**

Solvent (mixture)	Viscosity of fresh Ink [mPas]	Viscosity of Ink after 5 Weeks Storage at RT [mPas]	Additional Solvent for adjusted Viscosity [g/100 g ink]
EPr	55	60	55
EPr-EtOH-EtAc (1:1:1)	47	45	46
EtOH	45	55	45
EtAc-EtOH (1:1)	45	50	44
EAc	45	35	42

Diethylether is defined as standard solvent with a corresponding evaporation index of 1 according to table 4. The NC ink guideline formulation listed in table 2 is based on ethanol (EtOH). The viscosity can be adjusted with ethyl acetate (EtAc) being a drying promoter or with ethoxy propanol (EPr) as retarding agent for the drying process.

3.2 Influence of Solvents on the Ink Rheology

In our lab study the best conditions regarding ink performance were obtained with a solvent mixture of ethoxy propanol - ethanol - ethyl acetate (1:1:1) plotted as viscosity curves in figure 8a, without evaluating the thinning factor of the respective solvents.

Figure 8a
Rheology Curves of final Ink after Adjustment with additional Solvents

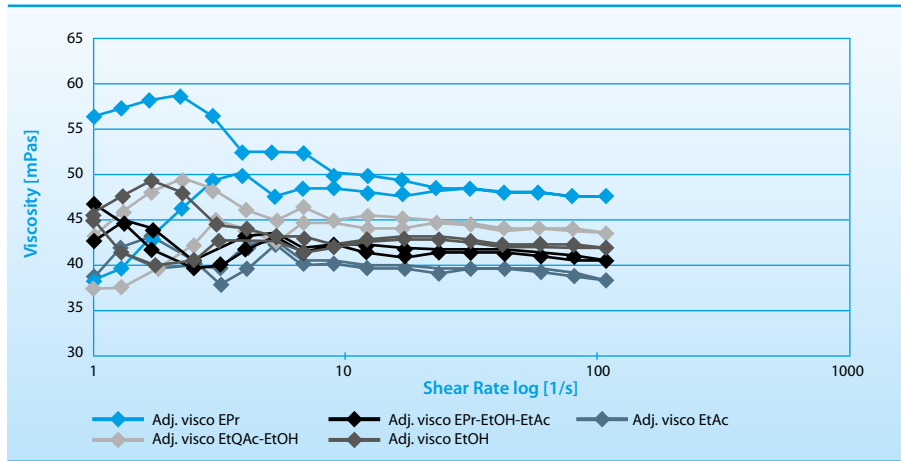

Figure 8b
4 mm Flow Cup according to DIN EN ISO 2431



The viscosity adjusted ink prepared with EPr-EtOH-EtAc (1:1:1) shows enhanced print performance in terms of 10% increased gloss and 4% higher optical density (figure 9) using the same ink base. The flow time is measured in a standardized matter by means of a 4mm DIN flow cup at 20°C ambient temperature (figure 8b). The viscosity adjustments lead to flow times of 17 sec.

Figure 8c
Rheometer from Anton Paar Rheoplus MCR 301



Figure 9
Optical Density and Gloss Values for 6 µm Drawdowns based on PRINTEX® 35 BEADS without Dryer measured over White

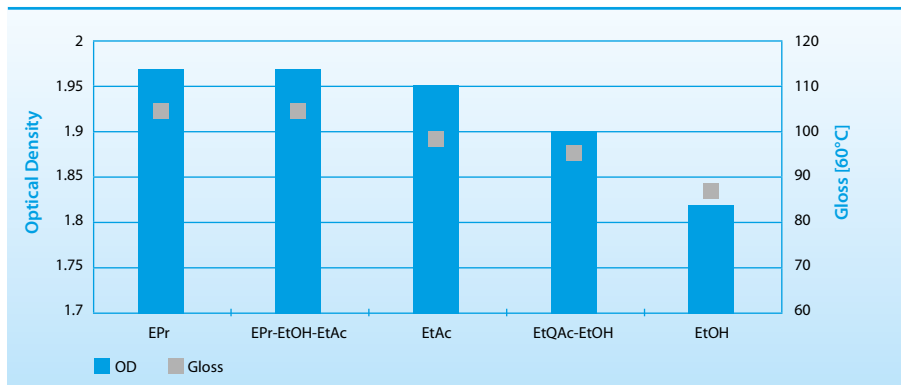

Not only the print performance could be enhanced by using the appropriate solvent mixture EPr-EtOH-EtAc (1:1:1), but also the viscosity level of the final ink remains stable (table 5), which is essential regarding print viscosity in comparison to the purely ethanol based ink.

3.3 Storage Stability of Carbon Black Ink Concentrate

In a pigmented system it is essential to maintain the viscosity on a stable level over time to be used as concentrate in blending stations. In order to guarantee the use of black bases in holding tanks of mixing stations, the viscosity levels during storage time neither should decrease nor increase significantly.

Before the preparation of final inks, it is important to check the long term stability of the corresponding base and let-down. PRINTEX® 35 BEADS was tested in our standard NC based flexo formulation and stored between 1 and 4 weeks at 40°C. Once per week the viscosity were measured and compared with a fresh reference and the black base stored at room temperature (figure 11). These viscosity profiles can be assigned to an almost newtonian fluid.

Figure 11
Rheology Curves of Ink Bases mixed with Let Down based on PRINTEX® 35 BEADS without Storage Time and after different Storage Conditions

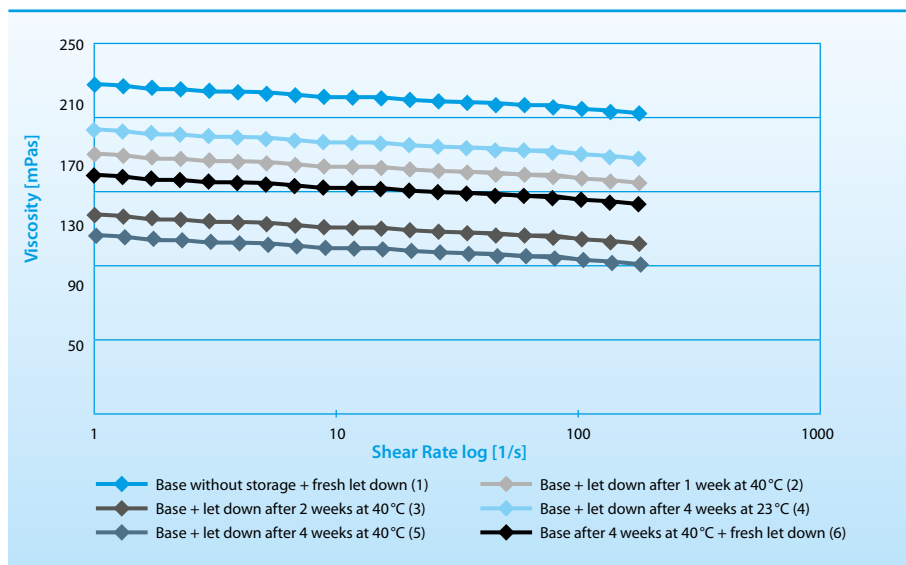

The optical density and gloss of final inks were measured for each sample, in order to see a possible trend depending on storage conditions. Although the initial viscosity level of the base without storage is higher compared to the viscosity after 4 weeks storage time, the coloristic parameters remain constant (figure 12). The ink concentrates as

well as the final inks can be considered as stable without an impact on product properties, regarding potential re-agglomeration or post-wetting of the pigment. This can be explained by the tailor made formulation for PRINTEX® 35 BEADS and the degree of dispersion being at the optimum level.

Figure 12
Optical Density and Gloss Values for 12 µm Drawdowns based on PRINTEX® 35 BEADS without Dryer over white after different Storage Conditions

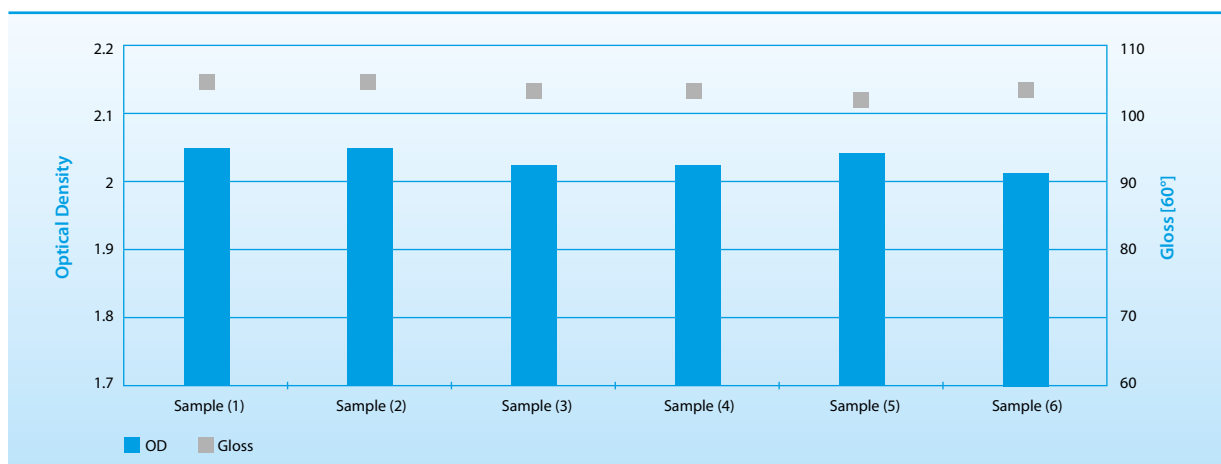

4 Variation of Printing Parameters

The specific printing technology refers to the corresponding end application. In case of solvent based packaging materials the final ink can be printed by the flexographic or gravure process, which were both tested at lab scale. All drawdowns published in chapter 2 and 5 were performed with the K-control coater (flexo) for PRINTEX® 35 BEADS and PRINTEX® 55 BEADS. In case of the K-printing proofer (gravure) PRINTEX® 45 BEADS was tested in addition. The K-printing proofer offers the possibility to print 3 different film thicknesses in one application step. Depending on the ink film thicknesses following coloristic aspects were evaluated: hiding power respectively the degree of transparency and hue (undertone).

4.1 Application by K-Control Coater

The standard method to apply the ink as drawdown in the OEC lab is done by the so-called K-control coater (figure 13a) by means of meter bars under controlled conditions with speed 1 (2 m/min) at certain wet film thicknesses (6 μm or 12 μm bar). The substrate in use is a Leneta glossy cardboard (form C105).

Figure 13a

K-Control Coater with 6 μm Drawdown on white plain Paper

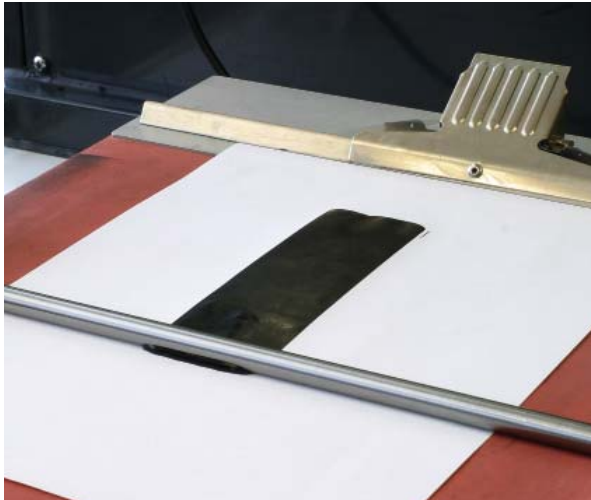

Figure 13b

K-Printing Proofer Device for Gravure and Flexo Printing Process from Erichson



4.2 Application by K-Printing Proofer

Another option is the K-printing proofer (figure 13b) in order to simulate the gravure printing process. By using this device the ink is transferred from an electronically engraved printing plate directly onto the substrate, which is attached to the rubber impression roller. The given screen ruling of 60 L/cm results in a corresponding resolution of 3600 dots/cm².

Figure 14a

Single 3 Wedge Plate (60 lines/cm) and Print Results



Figure 14b

Proof with 3 different Pattern Depths (engraving Depth)

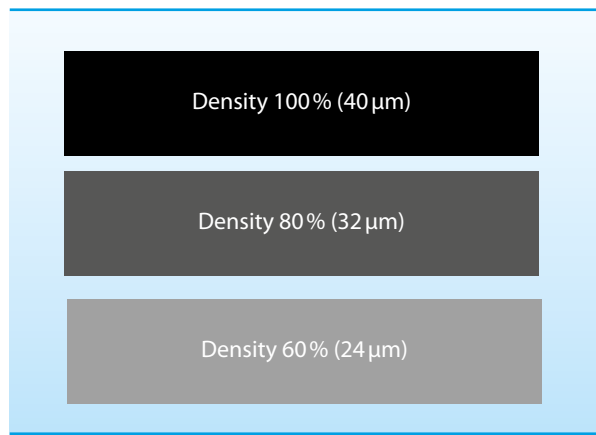

In the following case study the ink is applied at speed 7 (28 m/min) on a Leneta glossy cardboard and on 2 side calendered paper as substrates. The prints were done with PRINTEX® 35 BEADS, PRINTEX® 45 BEADS and PRINTEX® 55 BEADS, in order to see the influence of the color density

onto the hiding power and the resulting undertone, depending on the primary particle size of the Carbon Black. The printed area in full shade with a density of 100% presents the maximum hiding power.

Figure 15

Optical Densities of PRINTEX® 35 BEADS, PRINTEX® 45 BEADS and PRINTEX® 55 BEADS on Leneta Cardboard without Dryer depending on pattern Depths

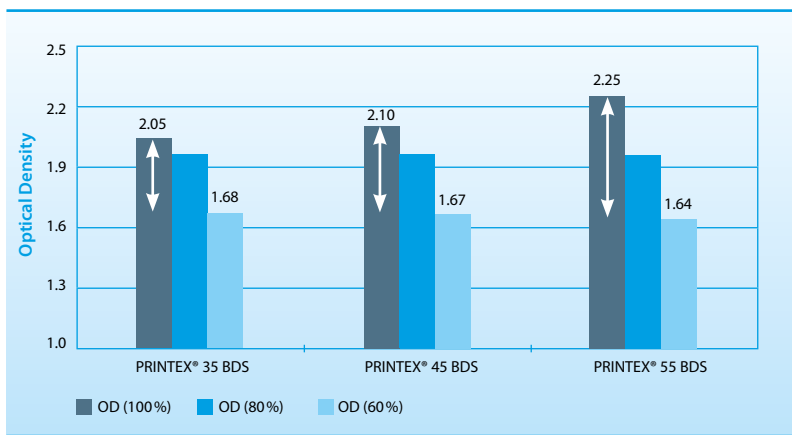

Optical densities at full shade (100%) in figure 15 increase from PRINTEX® 35 to PRINTEX® 55, because of the smaller average primary particle size. This trend is still valid for optical densities at 80%, but cannot be seen for optical densities at 60% any more. In the latter case the optical densities and therefore the hiding power is decreased in

a considerable way, that the printed layer becomes more transparent. Due to the finer sized particles in case of PRINTEX® 55, the difference of optical densities between 100% and 60% is bigger compared to PRINTEX® 35 or PRINTEX® 45 and can be considered as higher degree of transparency (table 6).

Table 6

Degree of Transparency as Delta between OD (100%) and OD (60%)

	PRINTEX® 35	PRINTEX® 45	PRINTEX® 55
Leneta glossy Cardboard	0.37	0.43	0.61
2 side calendered Paper	0.46	0.50	0.47

This increasing effect of transparency from PRINTEX® 35 to PRINTEX® 55 can also be observed by the changing undertone in figure 16. When considering the development of the undertone in terms of a* and b*, it is obvious

that there is a shift from green to red and respectively from blue to yellow by increasing transparency. This can also be explained by the fact that the hiding power decreases and therefore the printed ink gets more transparent.

Figure 16

Hue Values a* and b* for PRINTEX® 35 BEADS, PRINTEX® 45 BEADS and PRINTEX® 55 BEADS on Leneta Cardboard depending on Pattern Depths

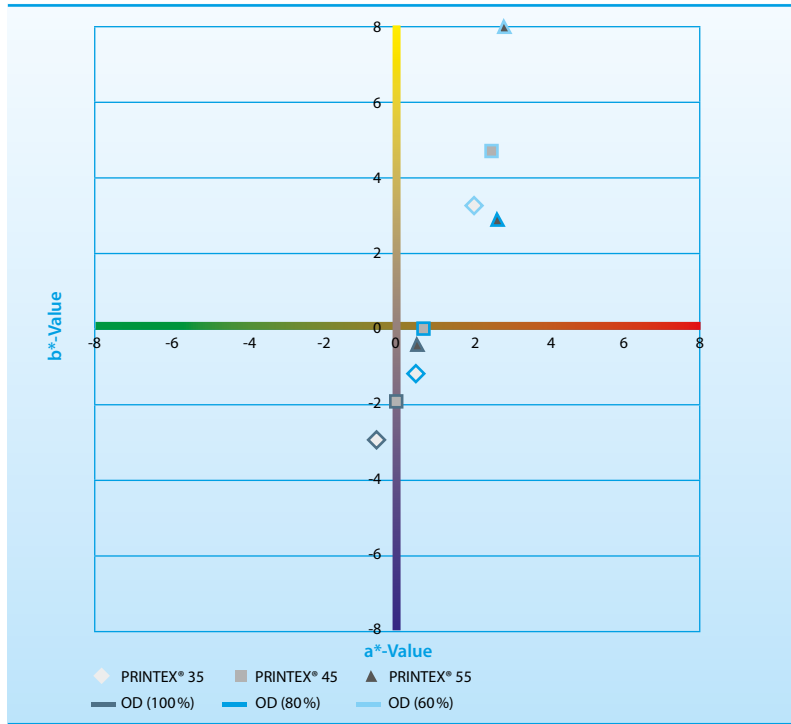

The optical densities in figure 17 show another trend, when printed on 2 side calendered paper compared to the Leneta glossy cardboard. Due to the different finish applied on top of the paper the surface porosity is higher in case of the calendered type of paper. Therefore the tendency of the Carbon Black to penetrate into the paper is higher, especially valid for low structured SCB tested in this content. The optical densities for all 3 PRINTEX® grades are lower compared to the values given on the glossy

substrate. From PRINTEX® 35 to PRINTEX® 45 there is still a slight increase in optical density, which is not the case for PRINTEX® 55 anymore. The finer sized and less branched aggregates of PRINTEX® 55 are stronger adsorbed by the porous structure of the paper. The degree of transparency expressed as delta between OD (100%) and OD (60%) on calendered paper, which corresponds to 0.5 in table 6, is not affected by the different Specialty Carbon Blacks.

Figure 17

Optical Densities of PRINTEX® 35 BEADS, PRINTEX® 45 BEADS and PRINTEX® 55 BEADS on 2 side calendered Paper without Dryer depending on Pattern Depths

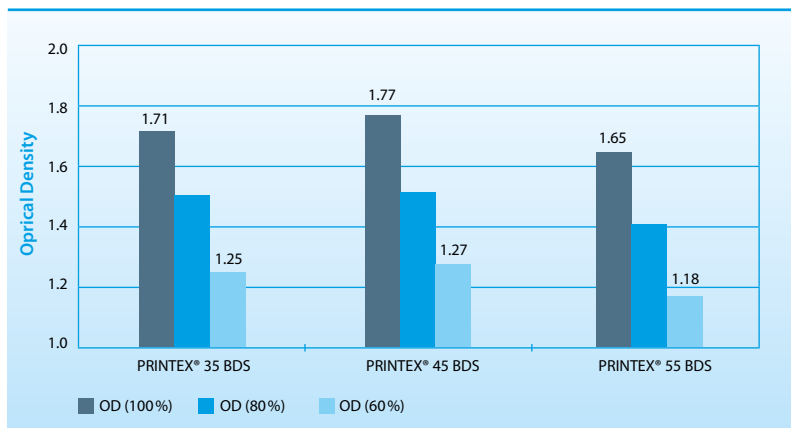

5 Colorimetric Measuring Systems and Conditions

In order to determine optical densities the measuring conditions have to be defined according to existing standards. In general the optical density is lightness dependent. For colorimetric measurements the setup of illuminant and viewing angle (CIE standard photometric observer) is the most important.

$$OD = \log\left(\frac{100}{Y}\right)$$

Figure 18

Optical Density as logarithmic Function of Reflection Y (lightness)

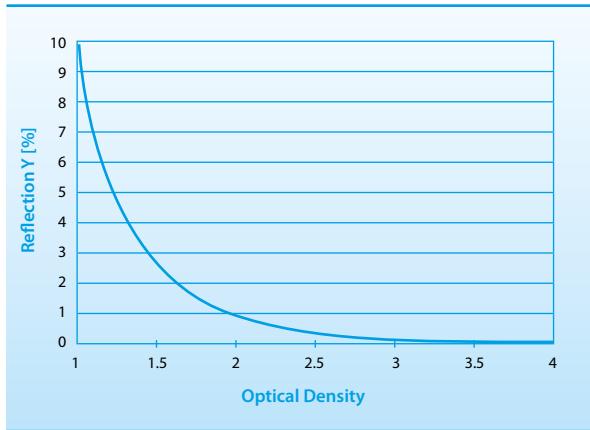

- D50 at first defined in 1974 and in 1975 certified by the ISO:3664 as daylight illuminant being the reference for the printing and graphic arts industry with CCT (correlated color temperature) of 5000K. D50 does not have CIE status of a standard illuminant.
- D65 defined in 1964, which has become the current standard daylight (average noon daylight from the northern sky) reference for the industry of various application with a CCT of 6500K described and referenced in ISO:3668, ASTM 1729 and DIN 6173-2.

The following graph in figure 19 shows the difference in spectral distribution between D50 and D65 illuminants.

Figure 19

Relative Spectral Power Distributions of D50 and D65 standard Illuminants

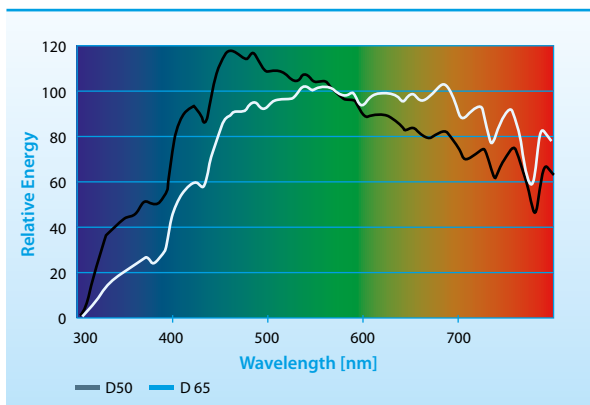

The spectral densitometer in use is equipped with polarization filters to measure real blackness without gloss components by elimination of specular reflection. The part of absorbed and accordingly reflected light depends on the dry film thickness.

Figure 20a

Degree of Reflection depending on dry Film Thickness

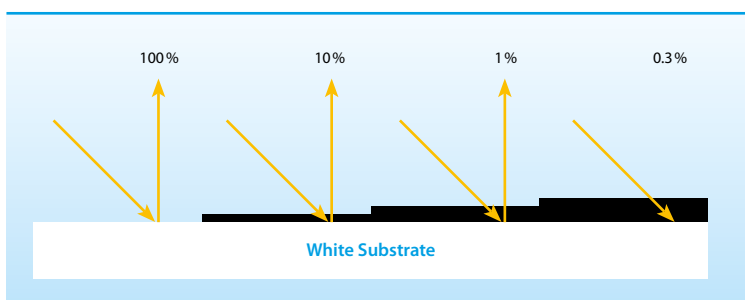

Figure 20b

Spectral Densitometer GretagMacbeth SpectroEye from x-rite



The potential influence of measuring parameters on the optical density respectively the L*-value has been studied by defining two basic setups regarding illuminant and viewing angle:

Illuminant/angle: D50/2° compared to D65/10°

Substrate: Leneta glossy cardboard measured over white contrast chart

Wet film thickness: 12 µm bar applied by K-control coater

The L*-values in figure 21 were determined with SpectroEye using a DIN filter, relative to absolute white, measured without polarizing filter. Under these conditions the influence of illuminant and viewing angle is very small and can be considered as not significant. As well the influence on a* and b* values is minor. The standardized OEC lab method focuses on D65/10°. However, if customers prefer D50/2° as measuring conditions for their quality control, the accuracy of L* or optical density values will not be negatively affected.

6 Summary and Outlook

The consideration of fundamental pigment properties, like the mean primary particle size of a Carbon Black, as one key parameter gives a first indication about the binder or additive demand. Further investigations how to achieve optimum dispersing conditions, were demonstrated by adjusting the pigment loading and dispersing time. The comparison between PRINTEX® 35 BEADS and PRINTEX® 55 BEADS showed that finer sized Carbon Black types need either more time or an optimized formulation regarding the binder/pigment ratio to be properly dispersed. All mentioned grades can be considered as low structured SCB and offer favorable performance regarding low viscosity levels, high gloss values and pigment loadings to be achieved.

The use of different solvents influences the ink viscosity as well as the drying time. Both parameters are important to be controlled for the respective printing technology, in particular for the speed of the printing machine. With a mixture of EPr-EtOH-EtAc the ink viscosity could be stabilized in a way to achieve higher optical density and gloss values by adjusting the flow time to 17 sec. The storage at increased temperature of 40°C had a small impact on the viscosity level of the black base.

Figure 21

L*-Values of PRINTEX® 35 BEADS and PRINTEX® 55 BEADS with Dryer over white depending on Illuminant and viewing Angle

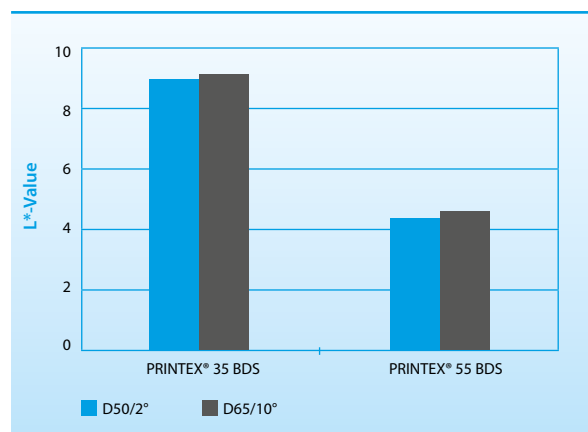

The drawdown application was mainly done by the K-control coater, which is used as standard printing device at lab scale. By using the K-printing proofer as printer with the possibility to vary the color density, it was proven that with higher optical density resulting in lower hiding power, the degree of transparency increased and the undertone shifted towards a yellow shade. Especially in case of PRINTEX® 55 BEADS the ink layer is getting more transparent compared to PRINTEX® 35 BEADS or PRINTEX® 45 BEADS due to the smaller average primary particle size of 25 nm.

In order to conclude, the comparison of colorimetric setups between D50/2° and D65/10° gave the same results regarding measured optical densities, demonstrated for PRINTEX® 35 BEADS and PRINTEX® 55 BEADS.

In order to achieve optimum Specialty Carbon Black performance in inks, formulation and application parameters need to be very well balanced. Our technical support team is pleased to discuss specific customer requirements.



The Americas

Orion Engineered Carbons LLC
4501 Magnolia Cove Drive, Suite 106
Kingwood, TX 77345
USA
Phone +1 832 445 3300

AMERICAS@orioncarbons.com

Europe/ Middle East/ Africa

Orion Engineered Carbons GmbH
Hahnstraße 49
60528 Frankfurt am Main
Germany
Phone +49 69 36 50 54 100

EMEA@orioncarbons.com

Asia Pacific

Orion Engineered Carbons Trading (Shanghai) Co., Ltd.
BM Intercontinental Business Centre, Room 3701-3702
100 Yutong Road
200070 Shanghai, China
Phone +86 21 6107 0966

APAC@orioncarbons.com

Global Corporate Headquarters

Orion Engineered Carbons S.A., 6 Route de Trèves, L-2633 Senningerberg, Luxembourg, Phone +352 27 04 80 60

www.orioncarbons.com

All information and statements contained herein are believed to be accurate, however Orion Engineered Carbons GmbH (as well as all other Orion Engineered Carbons group companies including Orion Engineered Carbons SA), its agents and/or affiliates give no warranty with respect thereto, including but not limited to any results to be obtained or the non-infringement of any proprietary right. Use or application of such information or statements or the material or systems described herein is at user's sole discretion and risk, and consequently user acknowledges that Orion Engineered Carbons GmbH (as well as all other Orion Engineered Carbons group companies including Orion Engineered Carbons SA), its agents and/or affiliates shall bear no responsibility or liability for same. Nothing herein shall be construed as a license of or recommendation for use, especially with concern to the potential infringement of any proprietary right. All sales are subject to the respective Standard Terms & Conditions of Sale issued by Orion Engineered Carbons GmbH or - as the case may be - another Orion Engineered Carbons group company, including but not limited to the Limited Warranty clauses contained therein.

© 2017 Orion Engineered Carbons GmbH

OEC-TI 1481-03/2017